

MIKU

MODEL:Mi6
PC GAMING CASE



FEATURES:

- 1.FRONT PANEL WITH ARGB DANCING BAR
- 2.360 LIQUID COOLING



REVISED HISTORY
Version 1.2
Edited by EVE
2022.11

SPECIFICATIONS

MODEL	Mi6
DIMENSIONS(L*W*H)	STRUCTURE:425*205*352MM PRODUCT: 440*205*352MM PACKAGE: 410*270*510MM
STRUCTURE THICKNESS	0.7MM
MATERIALS	SPCC 0.7MM LEFT SIDE PANEL: TEMPERED GLASS FRONT PANEL: METAL MESH
FORM FACTOR	M-ATX/ITX
DRIVE BAYS	5.25" CD ROM: 0 3.5" HDD: 1+2.5" SSD: 1 3.5" HDD: 0+2.5" SSD: 2
CPU MAX L	165MM
VGA MAX L	410MM(POWER SUPPLY SFX) 340MM(POWER SUPPLY ATX 180MM LENGTH) 320MM(POWER SUPPLY ATX 104MM LENGTH)
I/O PANEL	USB3.0*1+TYPE-C*1+HD AUDIO
PCI CARD SLOT	4
FAN SUPPORT	TOP: 3*12CM/2*14CM REAR: 1*12CM BOTTOM: 2*12CM
LIQUID COOLING SUPPORT	TOP: 24CM/28CM/36CM
POWER SUPPLY SUPPORT	FRONT MOUNT
WEIGHT	N.W.: 5.4KG G.W.: 6KG



PC GAMING CASE
Mi6

PICTURES

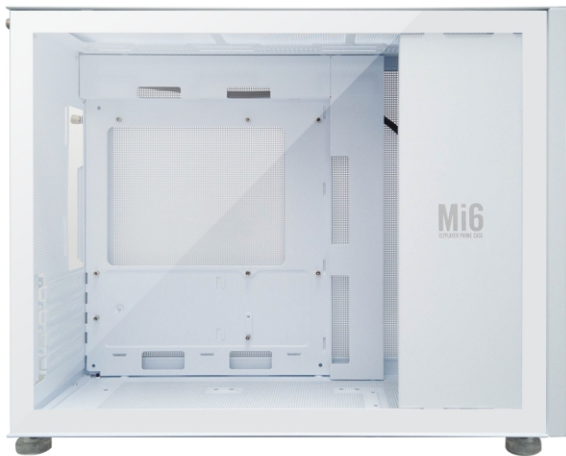
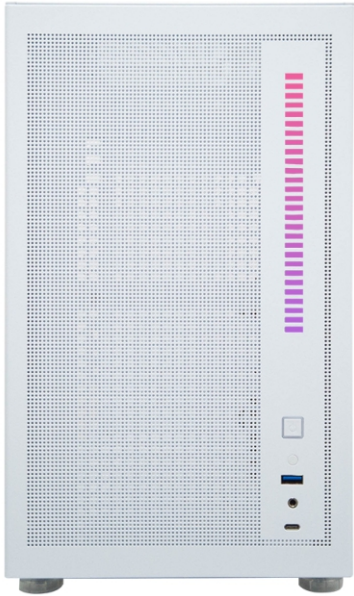

PC GAMING CASE
Mi6

USER MANUAL



1STPLAYER GAMING CASE
首席玩家游戏机箱
USER MANUAL 说明书

ASSEMBLY VIEW 装配视图

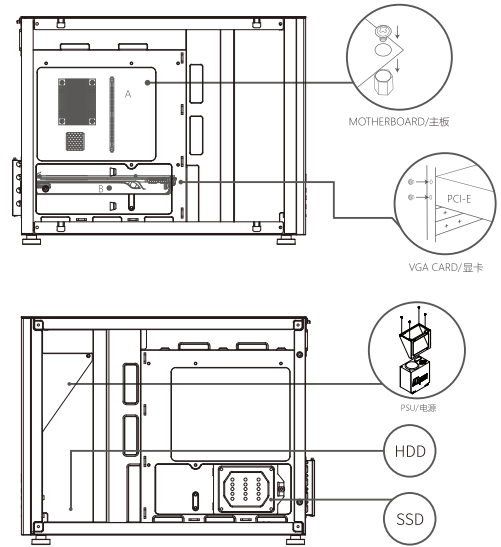

音乐律动模式说明

NO. 序号	MODE 模式	DIRECTION 方向	EACH MODE CONTAINS 9 DIFFERENT COLOUR 每个模式都有9种颜色选择
1	BOTTOM-UP BAR, NO WHITE DOTS 正向柱状, 无白点	----->>>	1.FULL COLOUR 全彩色
2	BOTTOM-UP BAR, 2 WHITE DOTS 正向柱状, 2个白点	----->>>	2.COLOUR FADING 渐变
3	SIDE TO MIDDLE BAR, NO WHITE DOTS 双向柱状, 无白点	<<<-----	3.RED 单色红
4	SIDE TO MIDDLE BAR, 1 WHITE DOT 双向柱状, 1个白点	<<<-----	4.GREEN 单色绿
5	SIDE TO MIDDLE BAR, NO WHITE DOTS BUT WITH BASE COLOUR 双向柱状, 不带白点带底色	<<<-----	5.BLUE 单色蓝
6	BOTTOM-UP BAR, 1 WHITE DOTS 正向柱状, 1个白点	----->>>	6.YELLOW 单色黄
7	SYNCHRONIZED TWO BAR WITH SAME DIRECTION 单向两段同步	<<<----- ----->>>	7.PURPLE 单色紫
8	TWO BAR OPPOSITE 单向两段同步	----->>>-----<<<	8.CYAN 单色青
			9.WHITE 单色白

DANCING BAR MODE AND ARGB MODE: 律动模式与ARGB模式切换:

DANCING BAR MODE/律动模式:
PRESS TO CHANGE TO THE DANCING BAR MODE.
短按 ●, 切换律动灯光形态

ARGB MODE/ARGB模式:
MOTHERBOARD SYNCHRONIZATION
跟随主板灯光

TURN OFF/关灯操作:
LONG PRESS THE BUTTON FOR 4 SECONDS, WHEN THE WHITE LIGHT
FLASHES 2 TIMES, IT WILL BE TURNED OFF.
长按 ● 4秒, 白光重复闪烁2下, 关机

TURN ON/开灯操作:
LONG PRESS THE BUTTON FOR 4 SECONDS,
WHEN THE WHITE LIGHT FLASHES 2 TIMES IT WILL, TURN ON
长按 ● 4秒, 白光闪烁2次, 开灯



PC GAMING CASE
Mi6

USER MANUAL

A. MOTHERBOARD/主板

1. THE HOLES OF MOTHERBOARD SCREW ALIGN WITH THE HEXAGON PILLARS
主板螺丝孔位对准六角铜柱
2. FIX THE MOTHERBOARD AND CASE WITH MOTHERBOARD SCREW
使用主板螺丝把主板与机箱固定
3. CPU MAX L: 165MM
机箱支持165MM高CPU散热器

MOTHERBOARD SPECIFICATIONS/主板规格



B. VGA CARD/显卡

1. INSERT THE VGA CARD TO THE PCI-E X4 CARD SLOT OF MOTHERBOARD
显卡插入主板PCI-E X4卡槽
2. FIX THE VGA CARD WITH HEXAGONAL SCREWS
六角螺丝固定显卡
3. RESERVING THE VGA CARD SLOTS FOR THE CASE, WHICH CAN ADJUST IT SELF
ACCORDING TO THE OUTPUT PORT OF VGA CARDS
机箱预留显卡卡槽,可根据显卡输出口自行调节
4. VGA MAX L: 410MM
机箱支持410MM长

C. POWER SUPPLY/电源

1. PSU FRONT MOUNT
前置电源仓
2. THE HOLES OF PSU ALIGN WITH THE RESERVED HOLE FOR CASE
电源孔位对准机箱预留的电源孔位
3. FIX WITH THE HEXAGONAL SCREWS
用六角螺丝固定

D. HDD

1. SUPPORT 3.5"HDD*1 支持3.5"HDD*1
2. THE SCREW HOLES OF HDD ALIGN WITH THE HDD HOLES, LOCKED THE HDD SCREW/HDD
螺丝孔位对准HDD孔位,锁上HDD螺丝

E. SSD

1. SUPPORT 2.5"SSD*1 支持2.5"SSD*1
2. THE HOLES OF SSD ALIGN WITH THE RESERVED HOLE FOR CASE/SSD螺丝孔位对准SSD孔位,锁上SSD螺丝
3. FIX SSD WITH THE MOTHERBOARD SCREWS 用主板螺钉固定SSD

F. LIQUID COOLER/冷排

1. TOP: 24CM 28CM 36CM 支持顶部 24CM 28CM 36CM 冷排

FAN/风扇

1. TOP: 3*12CM/2*14CM 支持顶部 3*12CM/2*14CM 机箱风扇
2. REAR: 1*12CM 支持后置 1*12CM 机箱风扇
3. BOTTOM: 2*12CM 支持底部 2*12CM 机箱风扇



PC GAMING CASE
Mi6